

LV8548M

Bi-CMOS integrated circuit 12V Low Saturation Voltage Drive Forward/Reverse Motor Driver

Overview

The LV8548M is a 2-channel low saturation voltage forward/reverse motor driver IC. It is optimal for motor drive in 12V system products and can drive either two DC motors, one DC motor using parallel connection, or it can drive a stepping motor in Full-step and Half-step.

Functions

- DMOS output transistor adoption (Upper and lower total RON = 1Ωtyp)
- For one power supply (The control system power supply is unnecessary.)
- Our motor driver IC, LB1948M, and compatible pin
- It is possible to connect it in parallel (parallel, connected operation of drive ch).
- The compact package (MFP-10S) is adopted.
- V_{CC} max = 20v, I_O max = 1A
- Current consumption 0 when standing by
- Built-in brake function

Typical Applications

- Refrigerators
- Time Recorder
- Label Printer
- Vacuum cleaner
- POS Printer
- TOY

Pin Assignment

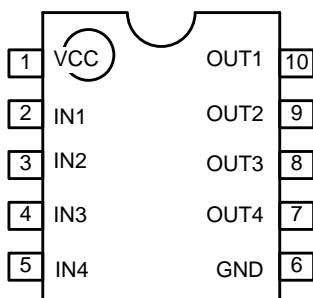

LV8548M
(Top View)

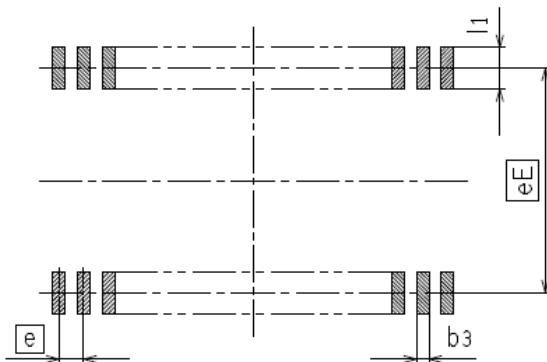

Package Dimensions

unit : mm (typ)
3086B

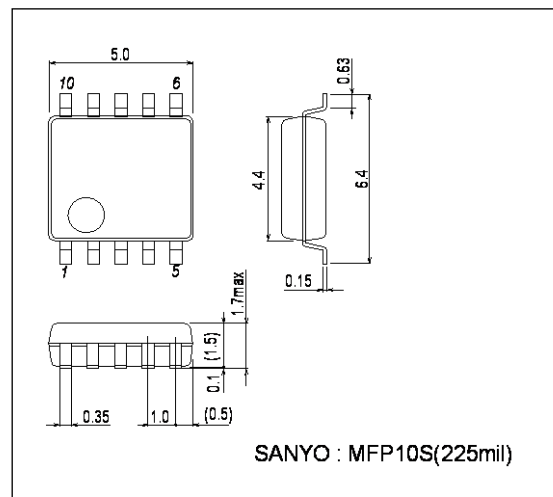

SANYO : MFP10S(225mil)

(Unit:mm)

Reference Symbol	MFP10S (225mil)
eE	5.70
e	1.00
b3	0.47
l1	1.10

Caution: The package dimension is a reference value, which is not a guaranteed value.

Block Diagram

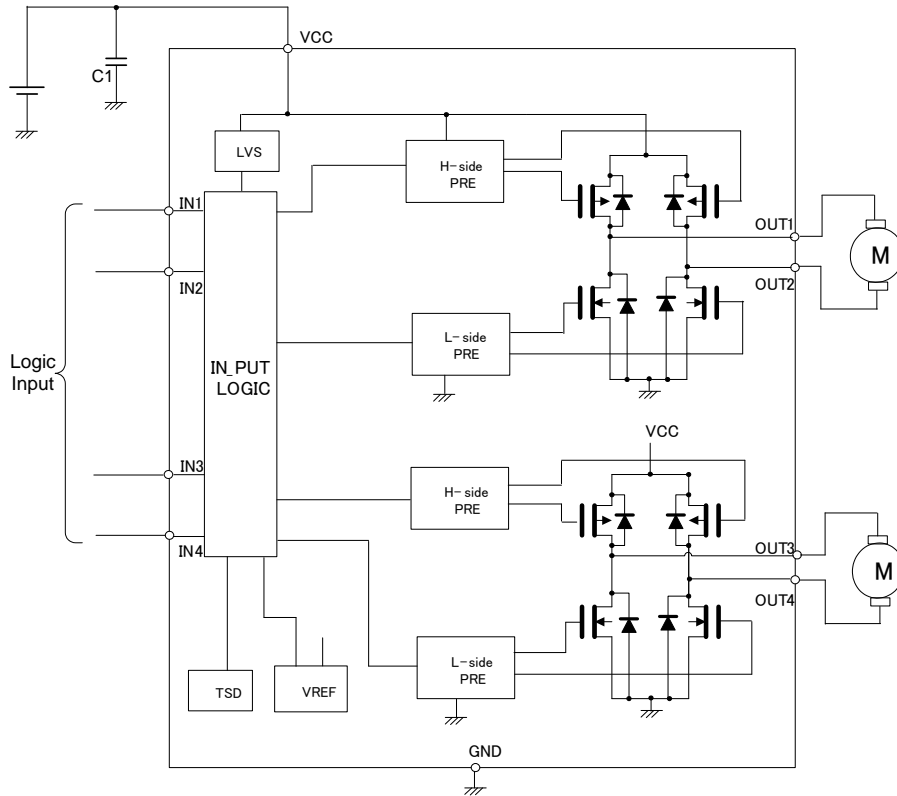

Figure1 Two DC motor drive

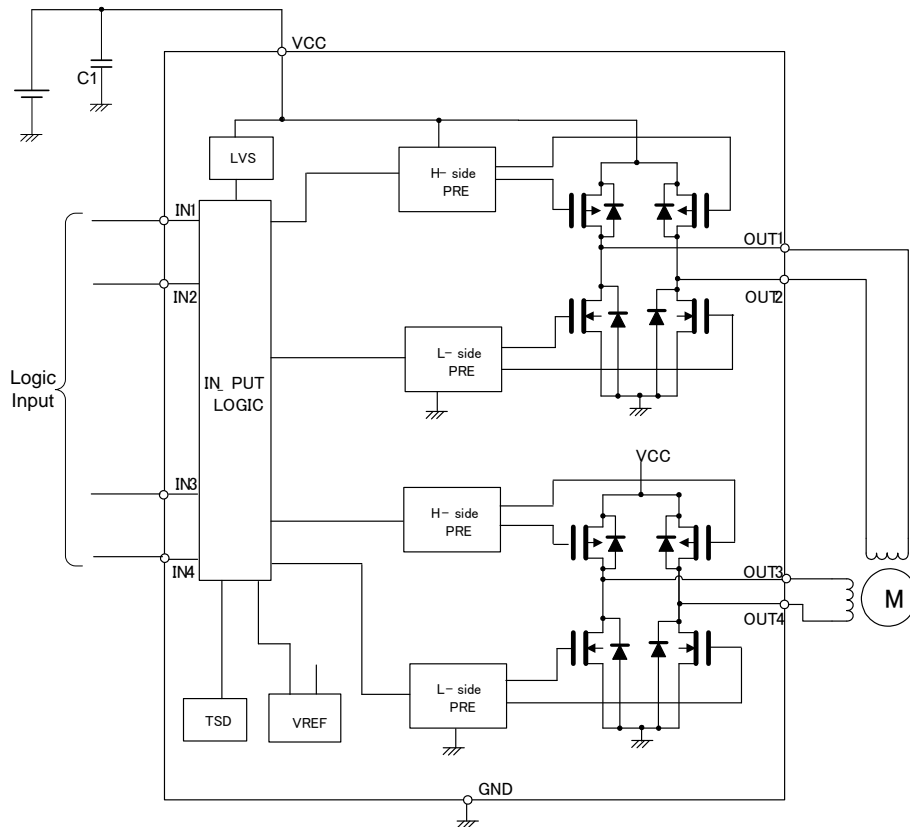

Figure2 One stepping motor drive

LV8548M

Specifications

Maximum Ratings at Ta = 25°C

Parameter	Symbol	Conditions	Ratings	Unit
Maximum power supply voltage	V _{CC} max		-0.3 to +20	V
Output impression voltage	V _{OUT}		-0.3 to +20	V
Input impression voltage	V _{IN}		-0.3 to +6	V
GND pin outflow current	I _{GND}	For ch	1.0	A
Allowable Power dissipation	P _d max	*	1.05	W
Operating temperature	T _{opr}		-30 to +85	°C
Storage temperature	T _{stg}		-40 to +150	°C

*: When mounted on the specified printed circuit board (57.0mm x57.0mm x 1.6mm), glass epoxy, both sides

Recommended Operating Range at Ta = 25°C

Parameter	Symbol	Conditions	Ratings	Unit
Power supply voltage	V _{CC}		4.0 to 16	V
Input "H" level voltage	V _{INH}		+1.8 to +5.5	V
Input "L" level voltage	V _{INL}		-0.3 to +0.7	V

Electrical Characteristics at Ta = 25°C, V_{CC} = 12V

Parameter	Symbol	Conditions	Ratings			Unit
			min	typ	max	
Power supply current	I _{CC0}	Standby mode IN1 = IN2 = IN3 = IN4 = "LOW"			1	μA
	I _{CC1}	It is "High" from IN1 as for either of IN4. Load opening		1.7	2.3	mA
Input current	I _{IN}	V _{IN} = 5V	35	50	65	μA
Thermal shutdown operating temperature	T _{tsd}	Design certification	150	180	210	°C
Width of temperature hysteria	ΔT _{tsd}	Design certification		40		°C
Low voltage protection function operation voltage	V _{thVCC}		3.3	3.5	3.65	V
Release voltage	V _{thret}		3.55	3.8	3.95	V
Output ON resistance (Upper and lower total)	R _{ON}	I _{OUT} = 1.0A	0.7	1	1.25	Ω
Output leak current	I _{Oleak}	V _O = 16V			10	μA
Diode forward voltage	V _D	I _D = 1.0A		1.0	1.2	V

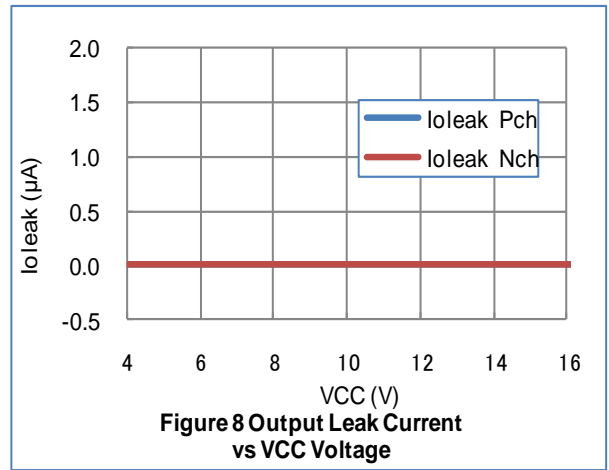
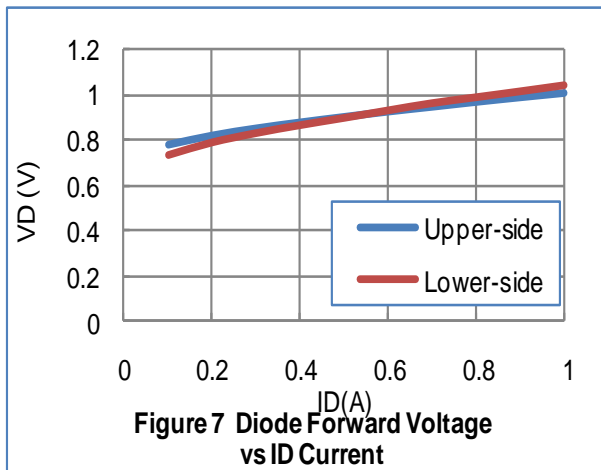
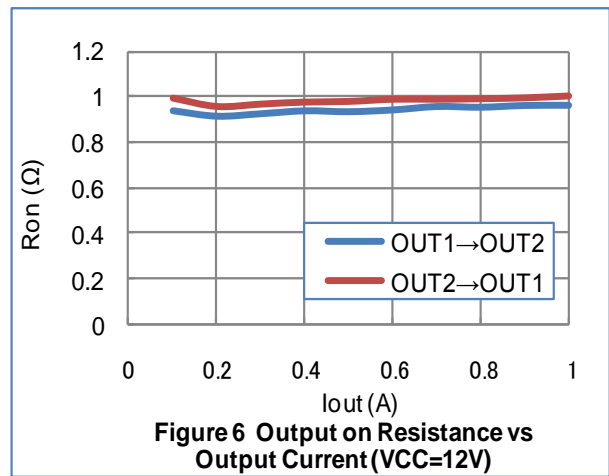
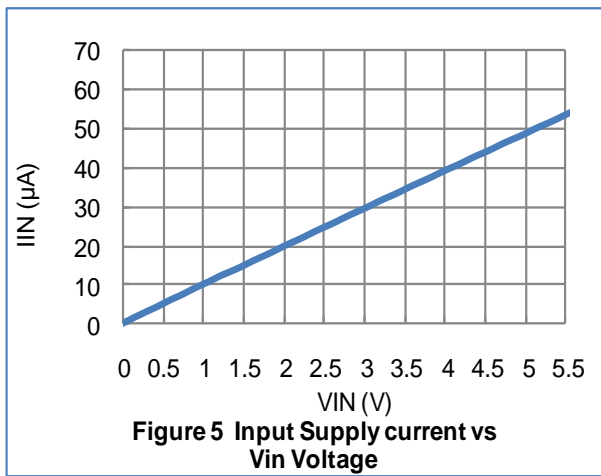
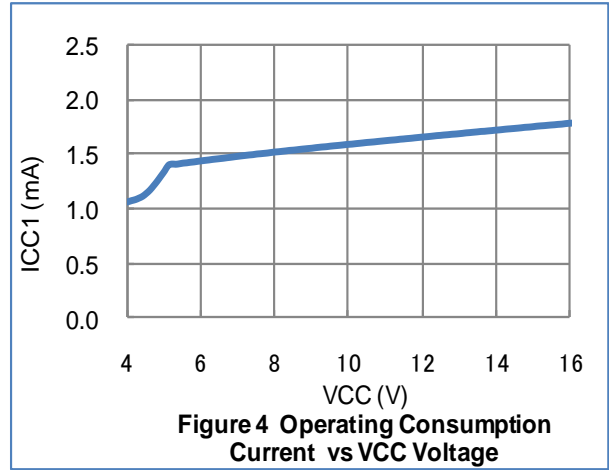
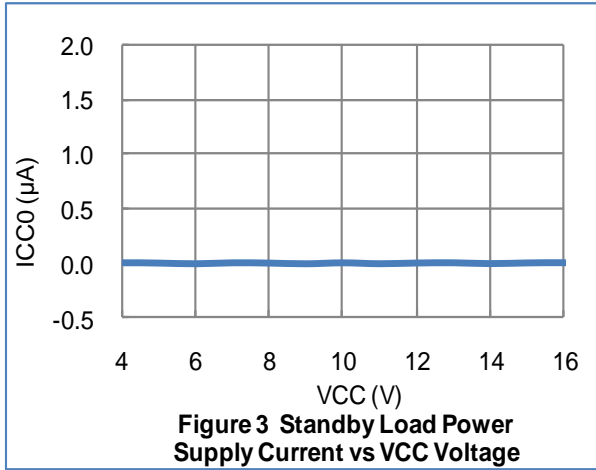

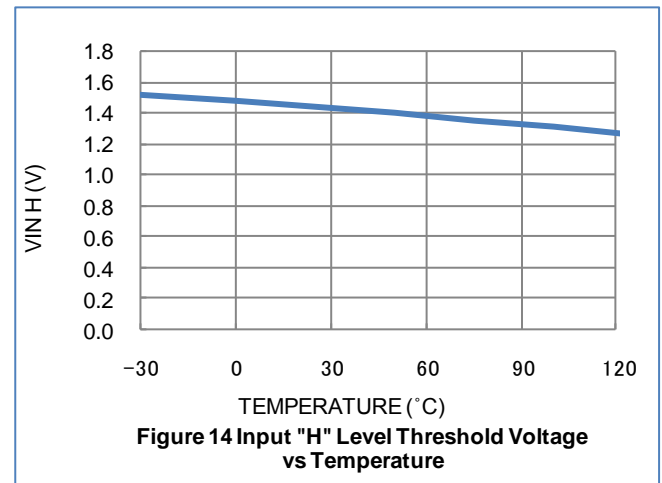
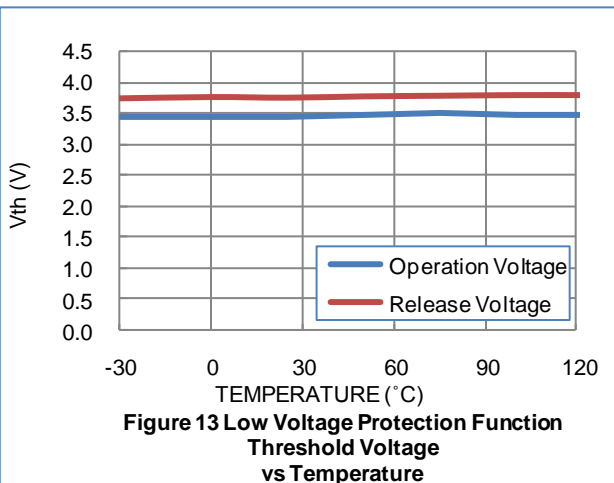
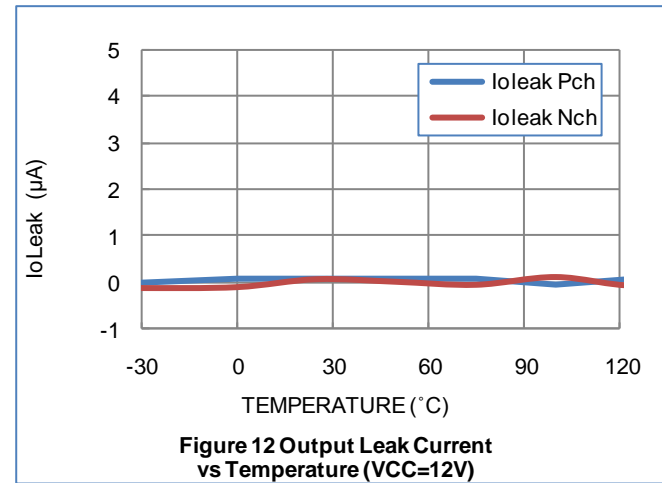
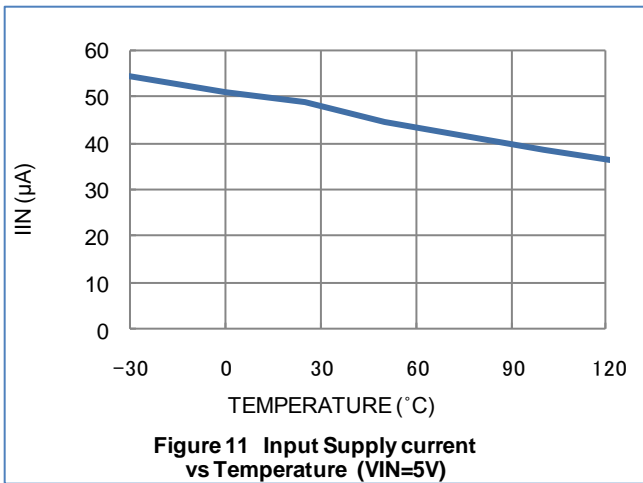
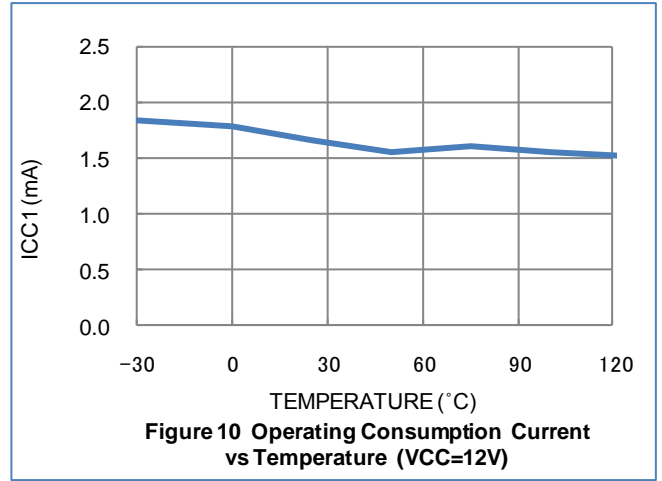
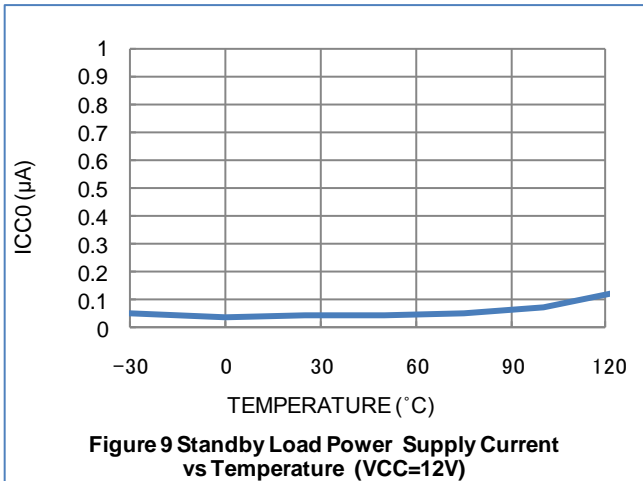

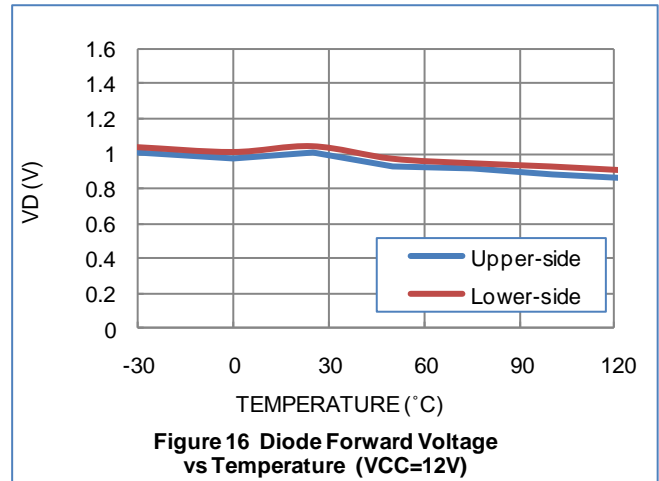
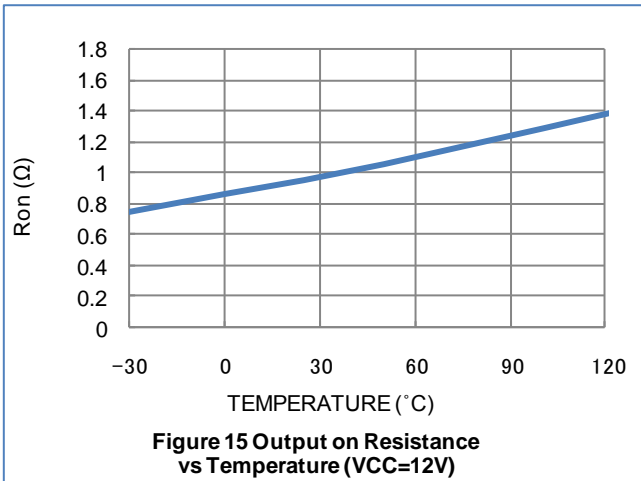

Pin function

Pin No.	Pin name	Pin function	Equivalent Circuit
1	VCC	Power-supply voltage pin. VCC voltage is impressed. The permissible operation voltage is from 4.0 to 16.0(V). The capacitor is connected for stabilization for GND pin (6pin).	
2	IN1	Motor drive control input pin. Driving control input pin of OUT1 (10pin) and OUT2 (9pin). It combines with IN2 pin (3pin) and it fights desperately. The digital input it, range of the "L" level input is 0 to 0.7(V), range of the "H" level input is from 1.8 to 5.5(V). PWM can be input. Pull-down resistance 100(kΩ) is built into in the pin. It becomes a standby mode because all IN1, IN2, IN3, and IN4 pins are made "L", and the circuit current can be adjusted to 0.	
3	IN2	Motor drive control input pin. Driving control input pin of OUT1 (10pin) and OUT2 (9pin). It combines with IN1 pin (2pin) and it uses it. PWM can be input. With built-in pull-down resistance.	
4	IN3	Motor drive control input pin. Driving control input pin of OUT3 (8pin) and OUT4 (7pin). It combines with IN4 pin (5pin) and it uses it. PWM can be input. With built-in pull-down resistance.	
5	IN4	Motor drive control input pin. Driving control input pin of OUT3 (8pin) and OUT4 (7pin). It combines with IN3 pin (4pin) and it uses it. PWM can be input. With built-in pull-down resistance.	
6	GND	Ground pin.	
7	OUT4	Driving output pin. The motor coil is connected between terminal OUT3 (8pin).	
8	OUT3	Driving output pin. The motor coil is connected between terminal OUT4 (7pin).	
9	OUT2	Driving output pin. The motor coil is connected between terminal OUT1 (10pin).	
10	OUT1	Driving output pin. The motor coil is connected between terminal OUT2 (9pin).	

Operation explanation

1. DCM output control logic

Input				Output				Remarks	
IN1	IN2	IN3	IN4	OUT1	OUT2	OUT3	OUT4		
L	L	L	L	OFF	OFF	OFF	OFF	Stand-by	
L	L			OFF	OFF			1CH	
H	L			H	L				Stand-by
L	H			L	H				Forward
H	H			L	L				Reverse
		L	L			OFF	OFF	2CH	
		H	L			H	L		Stand-by
		L	H			L	H		Forward
		H	H			L	L		Reverse

2. About the switch time from the stand-by to the operation

When IN1, IN2, IN3, IN4 are "L", this IC has completely stopped operating. After the time of reset (about 7μs of an internal setting) it shifts to a prescribed output status corresponding to the state of the input when the signal enters the input terminal.

Reset of about 7μs doesn't hang even if the motor is driven from the stand-by state when either CH drives and the output becomes an output status corresponding to the state of the input. As for full power TR between the reset time, turning off is maintained.

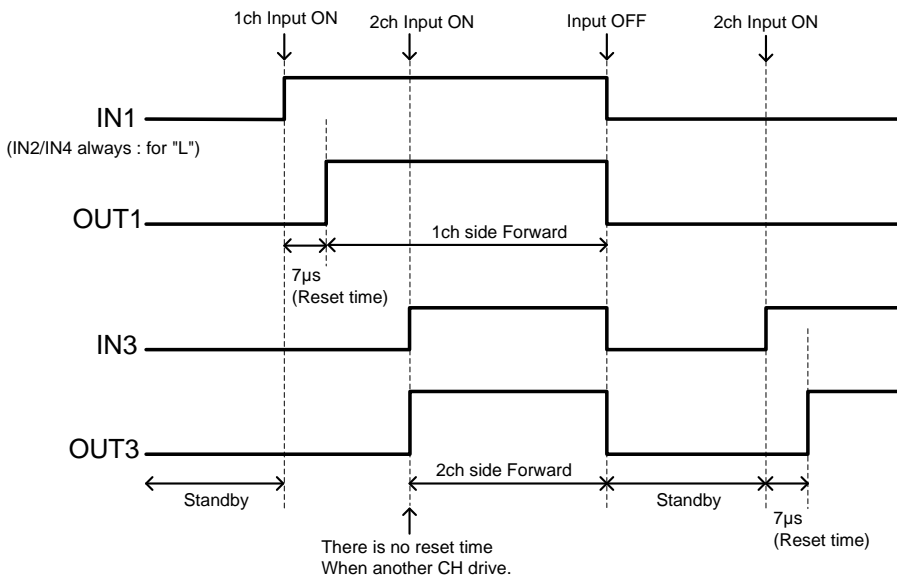

Figure17 switch time from the stand-by to the operation

3. Thermal shutdown function

The thermal shutdown circuit is incorporated and the output is turned off when junction temperature T_j exceeds 180°C. As the temperature falls by hysteresis, the output turned on again (automatic restoration). The thermal shutdown circuit does not guarantee the protection of the final product because it operates when the temperature exceed the junction temperature of $T_{jmax}=150°C$.

$$TSD = 180°C \text{ (typ)}$$

$$\Delta TSD = 40°C \text{ (typ)}$$

4. Low voltage protection function

When the power supply voltage is as follows typical 3.5V, the output does OFF.
When the power supply voltage is as above typical 3.8V, the IC outputs a set state.

Operation principal

- Full-Step Drive
Motor advances 90 degree by inputting 1 step.

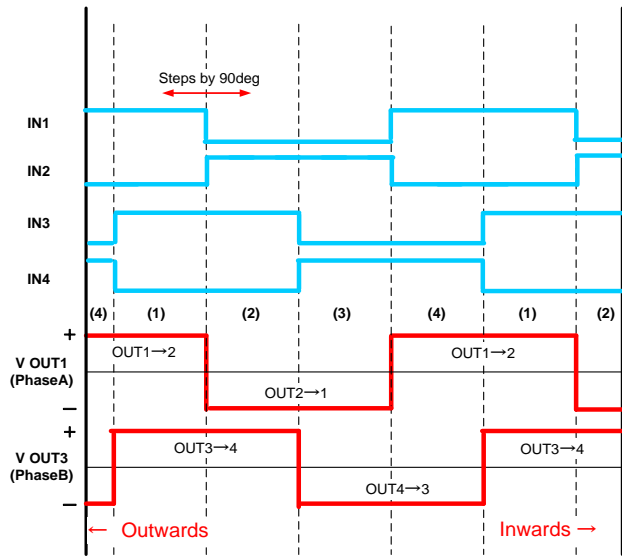

Figure 18. Full-Step Timing

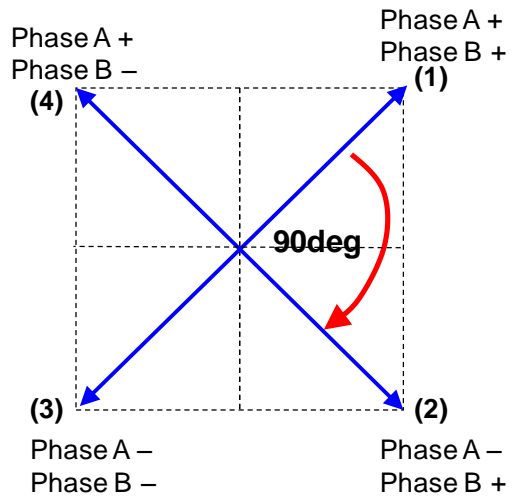

Figure 19. Motor electric angle (Full Step Drive)

- Half-Step Drive
Motor advances 45 degree by inputting 1 step.

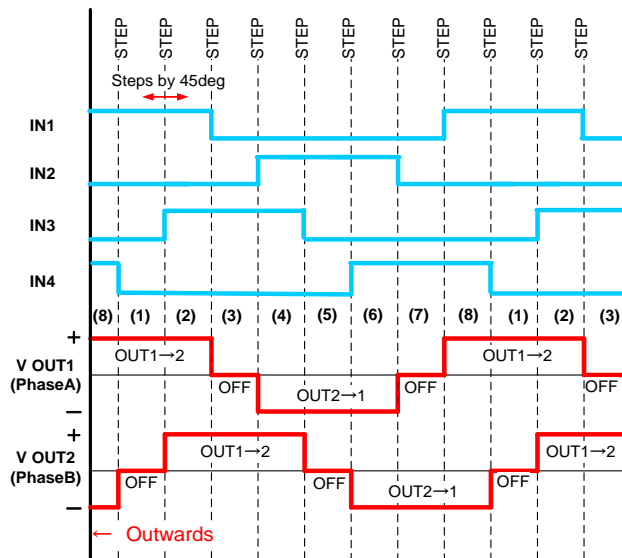

Figure 20. Half-Step Timing

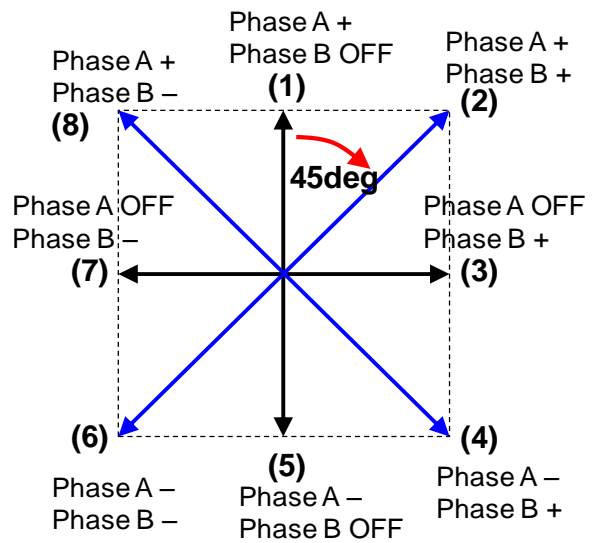
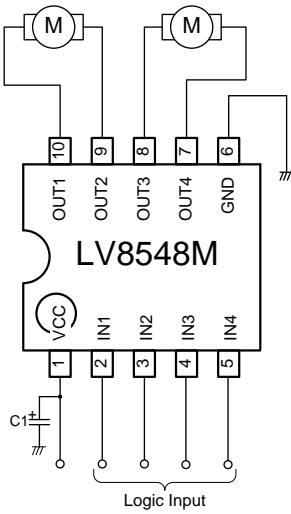

Figure 21. Motor electric angle (Half Step Drive)

LV8548M

Application Circuit Example

1. Example of applied circuit when two DC motor driving



2. Example of applied circuit when one stepping motor driving

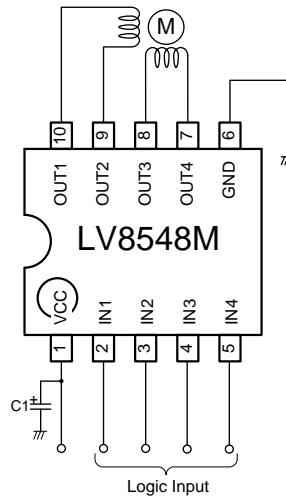

3. Example of applied circuit when connecting it in parallel

The use likened to H-Bridge 1ch is shown possible in the figure below by connecting IN1 with IN3, IN2 with IN4, OUT1 with OUT3, and OUT2 with OUT4. (I_O max = 2.0A, Upper and lower total $R_{ON} = 0.5\Omega$)

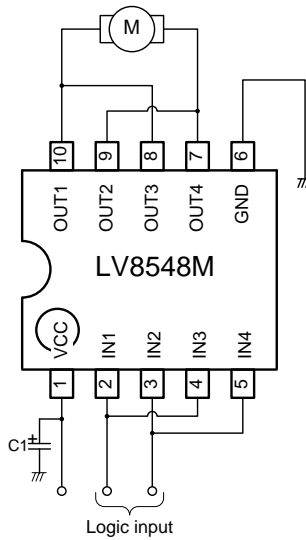

* Bypass capacitor (C1) connected between V_{CC} -GND of all examples of applied circuit recommends the electric field capacitor of $0.1\mu A$ to $10\mu A$.

Confirm there is no problem in operation in the state of the motor load including the temperature property about the value of the capacitor.

Mount the position where the capacitor is mounted on nearest IC.

Evaluation Board Manual

1. Evaluation Board circuit diagram

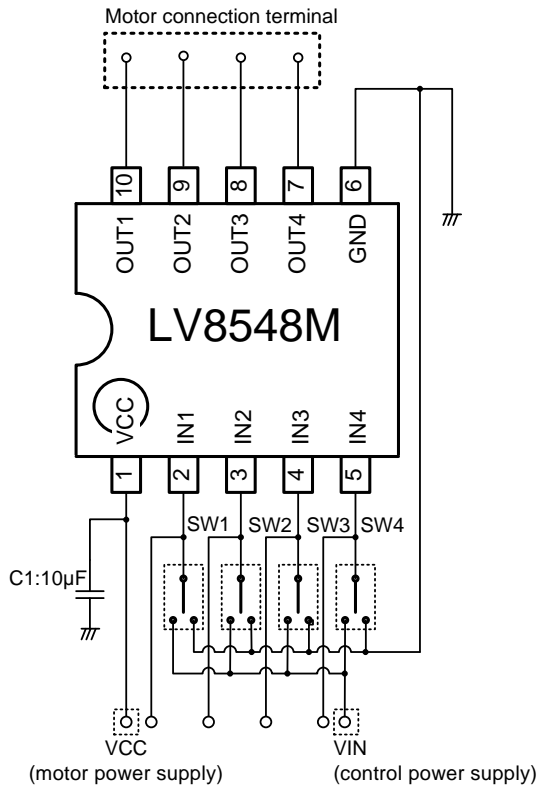

Bill of Materials for LV8548M Evaluation Board

Designator	Qty	Description	Value	Tol	Footprint	Manufacturer	Manufacturer Part Number	Substitution Allowed	Lead Free
IC1	1	Motor Driver			MFP10S (225mil)	SANYO semiconductor	LV8548M	No	Yes
C1	1	VCC Bypass capacitor	10µF 50V	±20%		SUN Electronic Industries	50ME10HC	Yes	Yes
SW1-SW4	4	Switch				MIYAMA	MS-621-A01	Yes	Yes
TP1-TP12	12	Test points				MAC8	ST-1-3	Yes	Yes

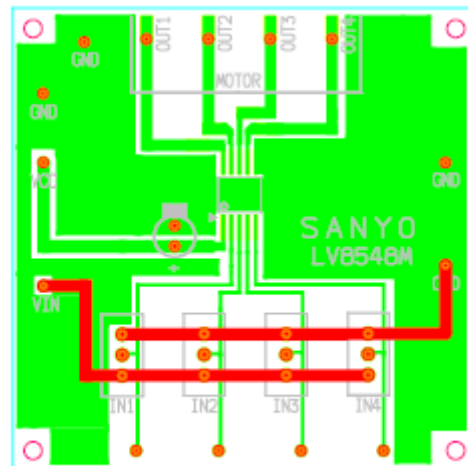
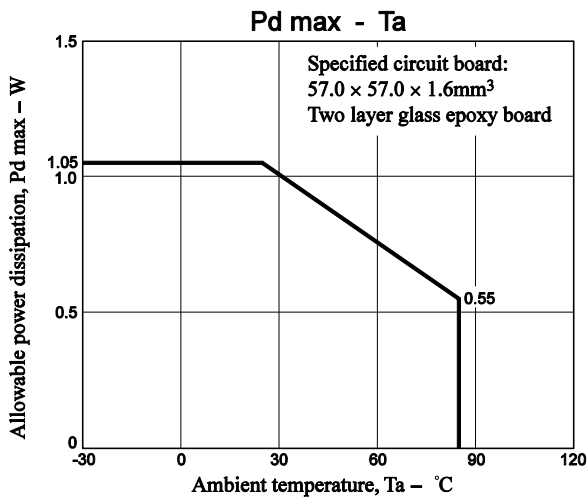

2. Two DC motor drive

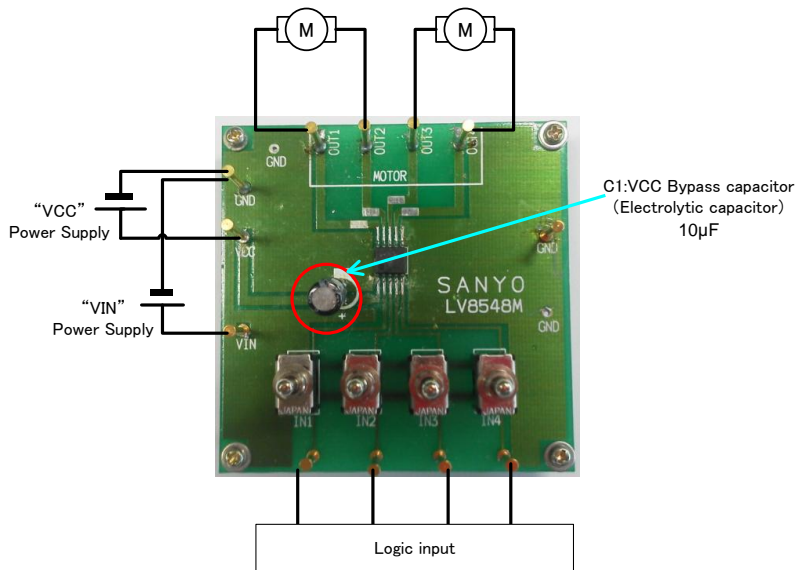

- Connect OUT1 and OUT2, OUT3 and OUT4 to a DC motor each.
- Connect the motor power supply with the terminal VCC, the control power supply with the terminal VIN. Connect the GND line with the terminal GND.
- DC motor becomes the predetermined output state corresponding to the input state by inputting a signal such as the following truth value table into IN1~IN4.
- See the table in p.8 for further information on input logic.

When you drive DC motor with LV8548M, caution is required to switch motor rotation from forward to reverse because when doing so, electromotive force (EMF) is generated and in some cases, current can exceed the ratings which may lead to the destruction and malfunction of the IC .

Coil current (I_{out}) for each operation is obtained as follows when switching motor rotation from forward to reverse.

- Starting up motor operation

$$\text{Coil current } I_{out} = (VCC - EMF) / \text{coil resistance}$$
 At startup, I_{out} is high because EMF is 0. As the motor starts to rotate, EMF becomes higher and I_{out} becomes lower.
- When switching motor rotation from forward to reverse:

$$\text{Coil current } I_{out} = (VCC + EMF) / \text{coil resistance}$$
 When EMF is nearly equal to VCC at a max, make sure that the current does not exceed I_{max} since a current which is about double the startup current may flow at reverse brake.
- Short brake:

$$\text{Coil current: } I_{out} = EMF / \text{coil resistance}$$
 Since EMF is 0 when the rotation of motor stops, I_{out} is 0 as well.

When you switch motor rotation from forward to reverse, if I_{out} is higher than I_{max}, you can operate short brake mode between forward and reverse either to slow down or stop the motor.

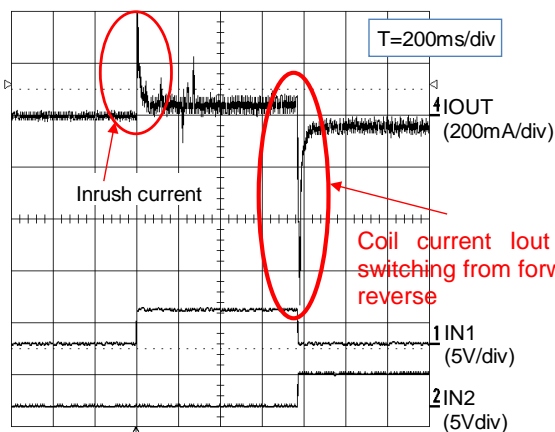

Figure22 Without Break MODE

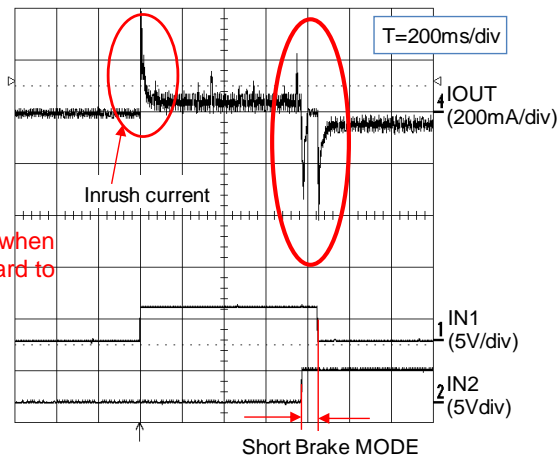

Figure23 With Break MODE

Input and output characteristics of H-Bridge

LV8548M can be driven by direct PWM control of H-Bridge by inputting PWM signal to IN.

However output response of H-Bridge worsens around On-duty 0%, which generates dead zone. As a result, IC control loses linearity.

If you intend to drive motor in such control range, make sure to check the operation of your motor.

Input-Output Characteristics of H-Bridge (reference data)

Forward/Reverse↔Brake

V_{CC}=12V

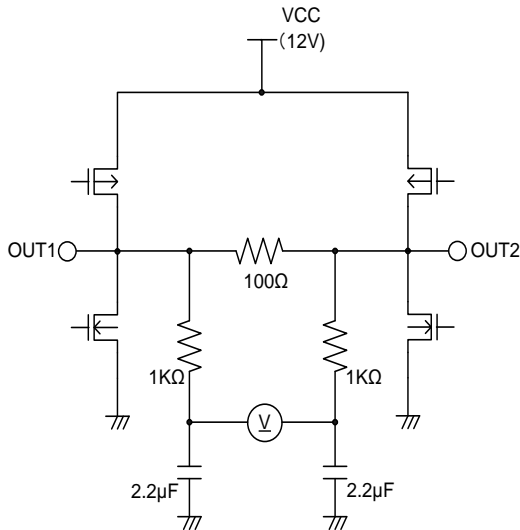

Figure24 Measurement connection diagram

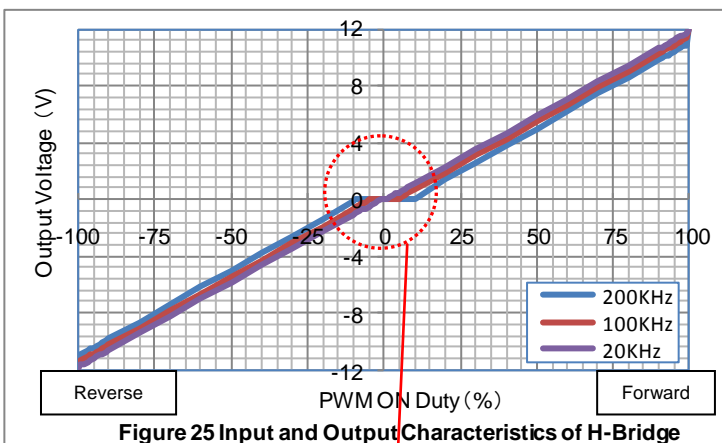

Figure 25 Input and Output Characteristics of H-Bridge

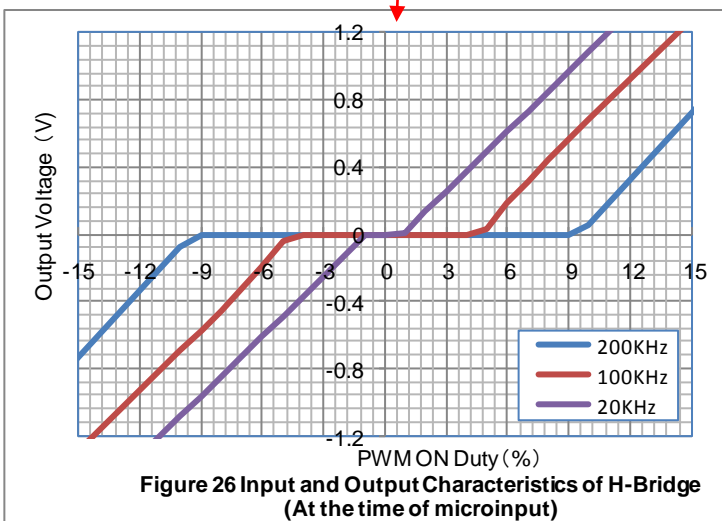
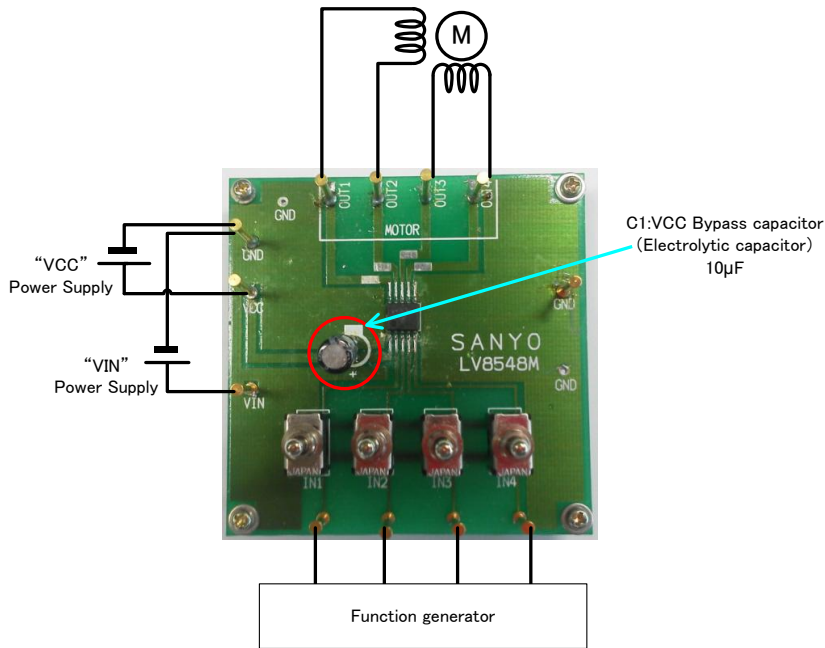

Figure 26 Input and Output Characteristics of H-Bridge (At the time of microinput)

LV8548M

3. One stepping motor drive



- Connect a stepping motor with OUT1, OUT2, OUT3 and OUT4.
- Connect the motor power supply with the terminal VCC, the control power supply with the terminal VIN. Connect the GND line with the terminal GND.
- STP motor drives it in a Full-Step, Half-Step by inputting a signal such as follows into IN1~IN4.
- For input signal to function generator, refer to p.9.
To reverse motor rotation, make sure to input signal to outward direction.

Waveform of LV8548M evaluation board when driving stepping motor

- Full-Step Drive

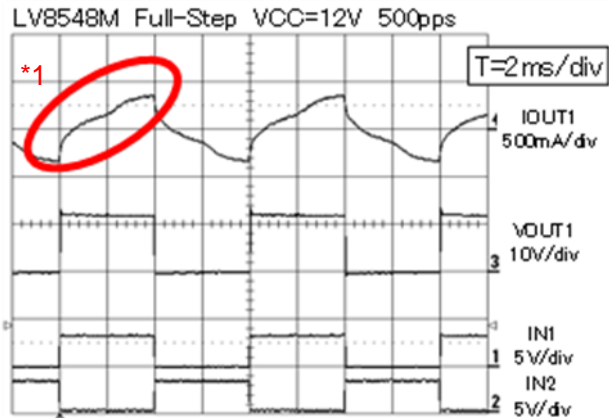
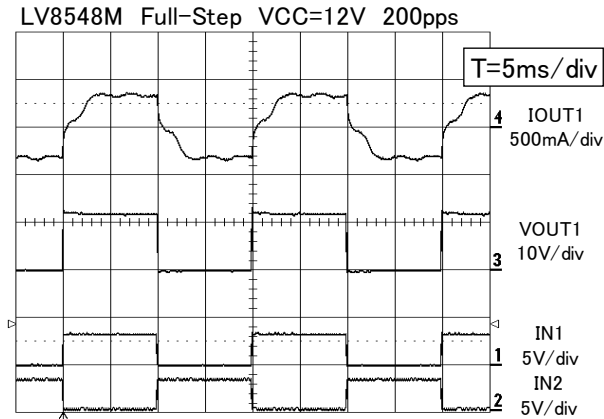

*1. When the motor rotation is at a high speed, current gradient increases by the inductance of motor (L).

LV8548M

•Half-Step Drive

LV8548M Half-Step VCC=12V 200pps

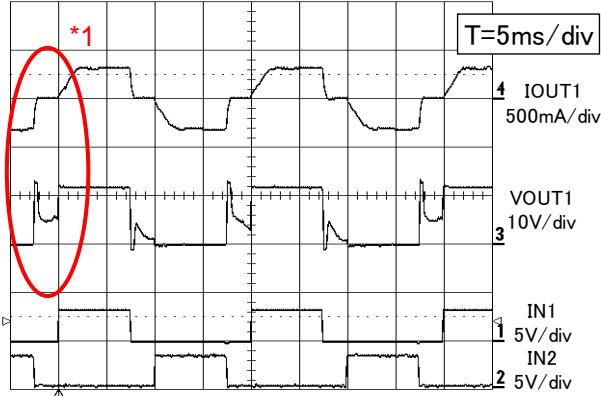

LV8548M Half-Step VCC=12V 500pps



*1.With Half-Step mode, voltage kick-back and electromotive force occur in current OFF period.

*2.When the motor rotation is at a high speed, current gradient increases by inductance of motor (L).

•IC surface temperature when a motor is in operation (reference)

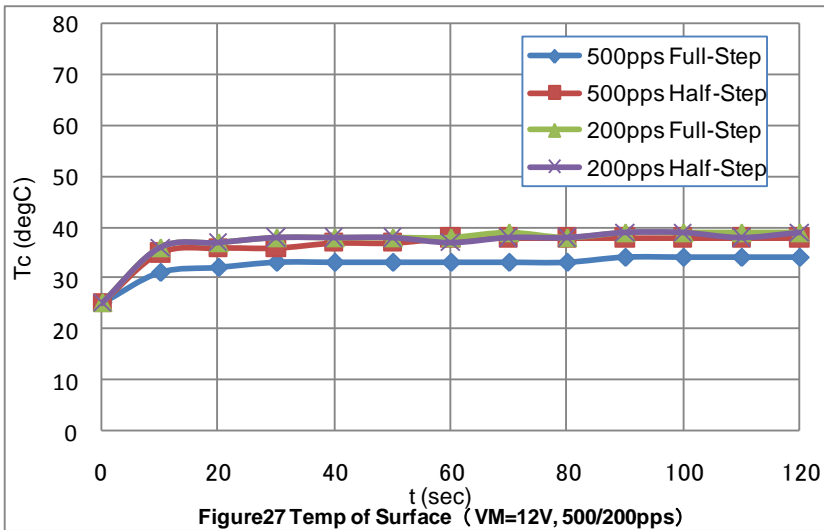

【Stepping motor driven by LV8548M】
 Motor diameter: 20.5mm
 Coil resistance: 30.8Ω

- Any and all SANYO Semiconductor Co.,Ltd. products described or contained herein are, with regard to "standard application", intended for the use as general electronics equipment (home appliances, AV equipment, communication device, office equipment, industrial equipment etc.). The products mentioned herein shall not be intended for use for any "special application" (medical equipment whose purpose is to sustain life, aerospace instrument, nuclear control device, burning appliances, transportation machine, traffic signal system, safety equipment etc.) that shall require extremely high level of reliability and can directly threaten human lives in case of failure or malfunction of the product or may cause harm to human bodies, nor shall they grant any guarantee thereof. If you should intend to use our products for applications outside the standard applications of our customer who is considering such use and/or outside the scope of our intended standard applications, please consult with us prior to the intended use. If there is no consultation or inquiry before the intended use, our customer shall be solely responsible for the use.
- Specifications of any and all SANYO Semiconductor Co.,Ltd. products described or contained herein stipulate the performance, characteristics, and functions of the described products in the independent state, and are not guarantees of the performance, characteristics, and functions of the described products as mounted in the customer's products or equipment. To verify symptoms and states that cannot be evaluated in an independent device, the customer should always evaluate and test devices mounted in the customer's products or equipment.
- SANYO Semiconductor Co.,Ltd. assumes no responsibility for equipment failures that result from using products at values that exceed, even momentarily, rated values (such as maximum ratings, operating condition ranges, or other parameters) listed in products specifications of any and all SANYO Semiconductor Co.,Ltd. products described or contained herein.
- SANYO Semiconductor Co.,Ltd. strives to supply high-quality high-reliability products, however, any and all semiconductor products fail or malfunction with some probability. It is possible that these probabilistic failures or malfunction could give rise to accidents or events that could endanger human lives, trouble that could give rise to smoke or fire, or accidents that could cause damage to other property. When designing equipment, adopt safety measures so that these kinds of accidents or events cannot occur. Such measures include but are not limited to protective circuits and error prevention circuits for safe design, redundant design, and structural design.
- In the event that any or all SANYO Semiconductor Co.,Ltd. products described or contained herein are controlled under any of applicable local export control laws and regulations, such products may require the export license from the authorities concerned in accordance with the above law.
- No part of this publication may be reproduced or transmitted in any form or by any means, electronic or mechanical, including photocopying and recording, or any information storage or retrieval system, or otherwise, without the prior written consent of SANYO Semiconductor Co.,Ltd.
- Any and all information described or contained herein are subject to change without notice due to product/technology improvement, etc. When designing equipment, refer to the "Delivery Specification" for the SANYO Semiconductor Co.,Ltd. product that you intend to use.
- Information (including circuit diagrams and circuit parameters) herein is for example only; it is not guaranteed for volume production.
- Upon using the technical information or products described herein, neither warranty nor license shall be granted with regard to intellectual property rights or any other rights of SANYO Semiconductor Co.,Ltd. or any third party. SANYO Semiconductor Co.,Ltd. shall not be liable for any claim or suits with regard to a third party's intellectual property rights which has resulted from the use of the technical information and products mentioned above.

This catalog provides information as of June, 2011. Specifications and information herein are subject to change without notice.